

Ferrolli



Opera

Modular power generator with high water volume



HIGHLY EFFICIENT MODULAR GENERATOR

With high water content for the building industry



The OPERA range consists of four modular condensing boilers featuring high water content, ideal for newly designed systems and also particularly suitable for the requalification of existing heat power plants.

The technical features and, in particular, the high water content of the OPERA range units make it possible to install them in any type of heating system, regardless of the designer's system choices. OPERA range generators can be installed as standalone or as up to three cascade modules for a maximum overall power of 960 kW.

The efficiency of the OPERA range enables the purchaser to apply for current tax benefits to upgrade climate-control systems.

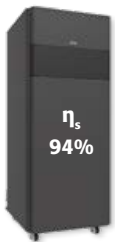

Opera

Romeo

external probe

System energy class A+

THE RANGE

the range consists of 4 generators, certified **B23**

mod. 70

HEAT INPUT 65.5 KW

EFFECTIVE HEAT OUTPUT (50°C-30°C) 69.9 KW

ERP CLASS A

mod. 125

HEAT INPUT 116.0 KW

EFFECTIVE HEAT OUTPUT (50°C-30°C) 125.0 KW

PMAX EFFICIENCY (50°C-30°C) 106.8

mod. 220

HEAT INPUT 207.0 KW

EFFECTIVE HEAT OUTPUT (50°C-30°C) 220.0 KW

PMAX EFFICIENCY (50°C-30°C) 106.8

mod. W 320

HEAT INPUT 299.0 KW

EFFECTIVE HEAT OUTPUT (50°C-30°C) 320.0 KW

PMAX EFFICIENCY (50°C-30°C) 106.8



THE IDEAL SOLUTION FOR EVERY PLANT

Design

The high water content of the boiler and its vertical design ensure that the OPERA range generators have very low pressure drops even at high flow rates, and allow them to operate with ΔT between delivery and return practically free, up to a maximum of 60°C at a flow rate close to zero.

All this means great system flexibility, which relieves the designer from the restrictions imposed by the type of generator.

It can also be connected directly to the system without interposing any separating devices, even in the case of multi-zone systems, usually characterised by significant variations in flow rates and in the Δt between flow and return to boiler.

These features make it particularly suitable in the cases of:

A) Plants with high water flows and modulating circulation systems

The generator, due to its physical characteristics, is perfectly suited to work on systems with high water flow rates to multiple “zones” operating simultaneously. The possibility of working in a practically unlimited range of Δt favours the combination with variable speed and low absorption circulation systems with advantages when calculating the energy efficiency of the building.

B) Requalification of existing plants

Being able to rely on a generator that integrates with any type of heat distribution system, obviously leaves a broader scope to the design. Moreover, it matches perfectly with the plate heat exchangers (characterised by very high pressure drops) placed between the boiler and the system, to prevent sludge from ending up in the boiler, compromising its proper functioning.

C) Replacing the old generator in the heat power plant

Its “independence” from the type of plant makes OPERA the best solution in terms of performance and technical characteristics when replacing the old heat generator.

The 4-star certification is a guarantee to increase the efficiency of the plant and consequently reduce consumption.

Water diagram

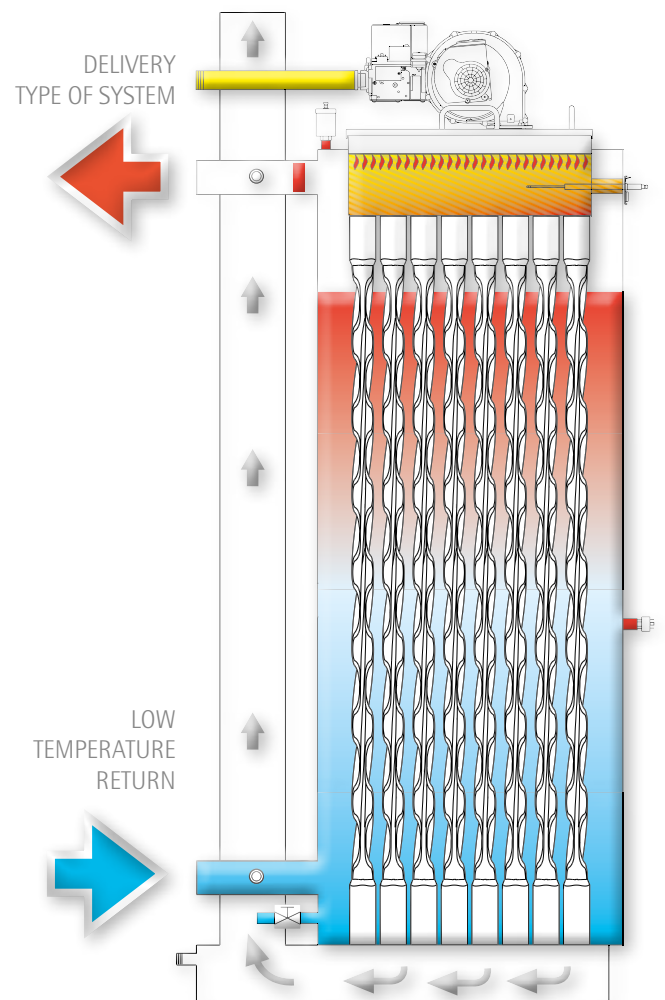

Water content

MOD. 70
160 litres
MOD. 220
380 litres

MOD. 125
265 litres
MOD. 320
530 litres



CHARACTERISTICS

Product benefits

- > Flue gas pipe heat exchanger, made of **AISI 316 Ti stainless steel**, with vertical configuration, with helical cross-section
- > Combustion unit with **class 6 emissions according to EN 15502-1**. The modules can run on Natural gas and LPG
- > Generator protection systems: **System double sensor (delivery and return) for operation at constant ΔT (adjustable up to 60°C)** / Flue gas safety sensor / Water pressure switch with minimum threshold at 0.8 bar
- > Air / Flue gas circuit with suction in the installation site and **check valve integrated** on the extraction unit to size the pressurised flue gas manifold
- > **Four heavy-duty floating wheels** fitted as per standard to facilitate discharge and mobility inside the thermal power plant. Positioning feet integrated in the wheel unit
- > **It reaches one of the highest seasonal space heating efficiencies** in its category: **η_s 94%**. Combined with the modulating remote control and the outdoor probe (optional) it reaches the **top efficiency class A+**
- > The **high water volume** of the generator allows the boiler to be connected to the system without the need for separating devices and allows for a **very high design Δt**
- > Management of the modules in bank set-up with self-configuring **MASTER / SLAVE system**
- > **Generator on and off setting** (which can be switched on and off in sequence or work simultaneously in parallel) through the control panel of the MASTER generator
- > Electronics on board the machine to manage a system with **two direct zones and one DHW storage tank** or systems with differentiated temperatures (direct and mixed) in combination with the FZ4 B temperature control unit
- > **RANGE RATED** certified generator to adjust the generated power to the system's needs by increasing the efficiency of the system and preserving the mechanics of the machine
- > The modules can be controlled and operated remotely: **Regulation of power or temperature with 0 - 10V signal** / Signalling of block alarm for safety and to resume operation / **OPENTHERM (OT) and MODBUS parameterisable communication protocols**
- > Electronic control of microprocessor combustion allows **1/5 modulation** on the single generator and 1/15 modulation for the maximum configuration (3 x 320 modules in bank set-up)

THE PRODUCT IN BRIEF



Remote control of boiler parameters via remote control



Device operates with **climatic control** and sliding system temperature (optional external temperature probe)



Device suitable for operation in a **partially protected place** with a minimum temperature of -5°C, as standard



Appliance certified as "range rated" according to UNI EN 483



Cascade operation as single equivalent generator



Minimum polluting emissions (**class 6 according to EN 15502-1**) as required by Directive ErP of 26.09.2018 (NOx emissions < 56mg/kWh)



This equipment is designed specifically to offer **particularly simple** installation and maintenance



Generator equipped with devices to **simplify handling** during shipping and installation



Stainless steel **exchanger**
Patented AISI 316 TI



OPERA

Components



- 1** Premix unit with flue gas backflow prevention check valve
- 2** Electronic control and user interface
- 3** Flue gas outlet
- 4** Flue gas thermostat
- 5** Condensation discharge manifold
- 6** Floating wheels with locking device
- 7** Air bleed valve
- 8** System delivery sensor
- 9** Water pressure switch
- 10** Safety valve fitting (not supplied)
- 11** System delivery
- 12** Generator drain cock
- 13** System return
- 14** System return probe
- 15** Gas inlet

HYDRAULIC, GAS FITTINGS AND FLUE GAS OUTLETS

MODEL		70	125	220	320
3	Flue gas outlet Ø (mm)	80	100	160	200
11	System delivery	1' 1/4	1' 1/4	2'	DN 65
13	System Return	1' 1/4	1' 1/4	2'	DN 65
15	Gas inlet	3/4'	1'	1'	1'
12	Boiler discharge	3/4'	3/4'	3/4'	3/4'



OPERA

The art of building



Aisi 316 Ti steel has been used in the construction of the heat exchanger and condensate collection tank to ensure maximum mechanical and corrosion resistance. The design and helical configuration of the heat exchanger tubes ensure a larger exchange surface, a better coefficient of heat transmission between water and flue gas, and a very low thermal load.

PREMIX COMBUSTION UNIT

OPERA is equipped with a full pre-mixing combustion unit, with a variable speed, **Natural gas or LPG-operated** variable speed fan. The particular shape of the front combustion burner and the fitted air/gas mixture diffusion grid ensure perfect distribution of the thermal load across the whole combustion chamber, protecting both the burner and the exchanger from any temperature difference.

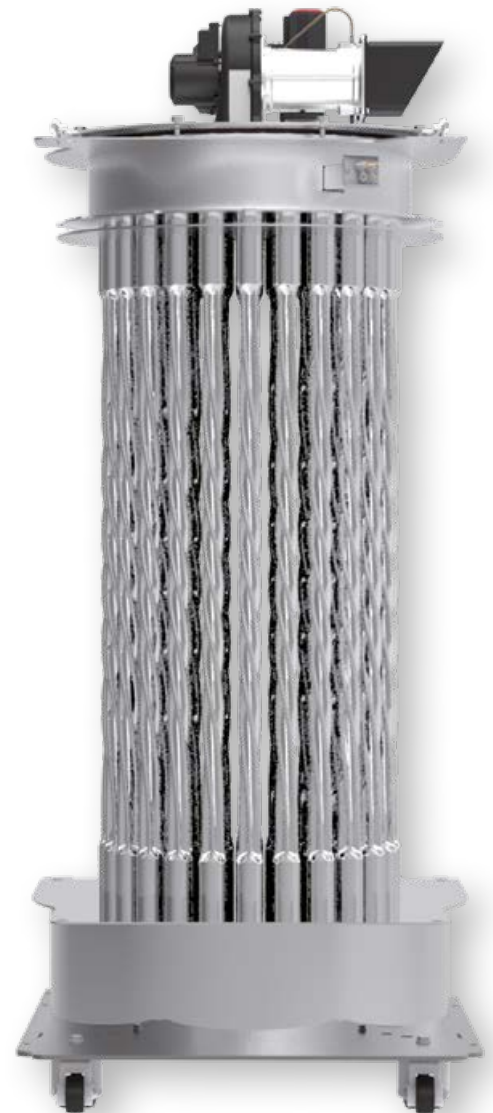

As a result of the extremely reduced vertical footprint of the burner, the exchanger can be fully exploited, with obvious benefits for condensation and stratification in the boiler.

FLUE GAS BACKFLOW VALVE

A valve equipped with a mobile shutter to prevent the return of flue gas through the boiler into the installation environment is installed as standard on the pre-mixing unit fan inlet.

This makes it possible to expel pressurised combustion products and consequently size the flue system more easily with pipes of smaller diameter compared to classic negative pressure systems.





OPERA

Control panel

Characterised by a large dot matrix display and keys to set the basic functions of the generator and to select the parameterisation menus.

The interface is designed to make it easier to read the parameters and browse the menus, both for the USER to adjust and set the basic functions and the TECHNICIAN for maintenance and advanced parameters.

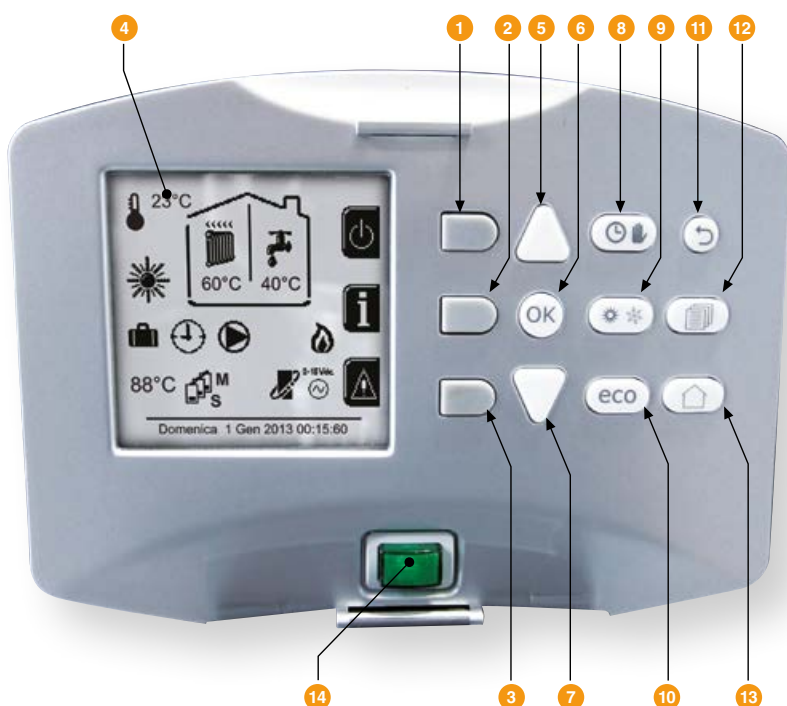

KEY

- 1 Contextual key 1
- 2 Contextual key 2
- 3 Contextual key 3
- 4 Dot matrix display (example of main screen)
- 5 Menu navigation key
- 6 Menu input/confirmation key
- 7 Menu navigation key
- 8 DHW/heating Manual/Automatic operation key
- 9 Summer/Winter mode selection key
- 10 Economy/Comfort mode selection key
- 11 Menu exit key
- 12 Main menu key
- 13 Home key (back to the main screen)
- 14 Main switch

CONTEXTUAL KEYS (det. 1, 2, 3) are grey, have no silk-screen printing and can have a different meaning based on the selected menu. Follow the instruction displayed (icons and texts), e.g. via contextual key 2 (det. 2) information of the device such as temperature sensors, operating outputs, etc. can be accessed.

DIRECT KEYS (det. 8, 9, 10) always have the same function

MENU/NAVIGATION KEYS

Menu/navigation keys (det. 5, 6, 7, 11, 12, 13) are used to scroll through the various menus implemented in the control panel

Two distinct levels of parameterisation can be accessed from the control panel's main menu:

USER level

Since it is not password-protected, it enables the "system manager" to set the operating mode of the single or cascade generator in order to sync them as much as possible with the type of system based on user requirements

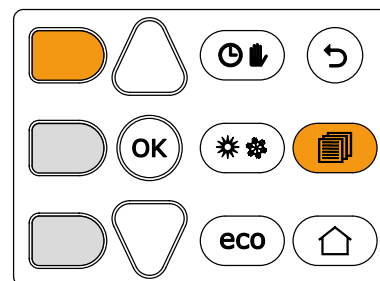

TECHNICIAN level

Since it is password-protected, it enables the "authorised technician" to check and modify the thresholds of each single component of the generator and boiler system.

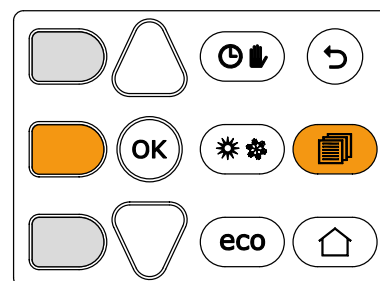



CHARACTERISTICS

Control electronics

For all "PROFESSIONAL" range high-power condensation heat exchangers, Ferroli uses a single electronic platform and the same interface panel that is able to manage correct operation and safety of the generator, cascade installation and the main components of a heating system for domestic hot water production.

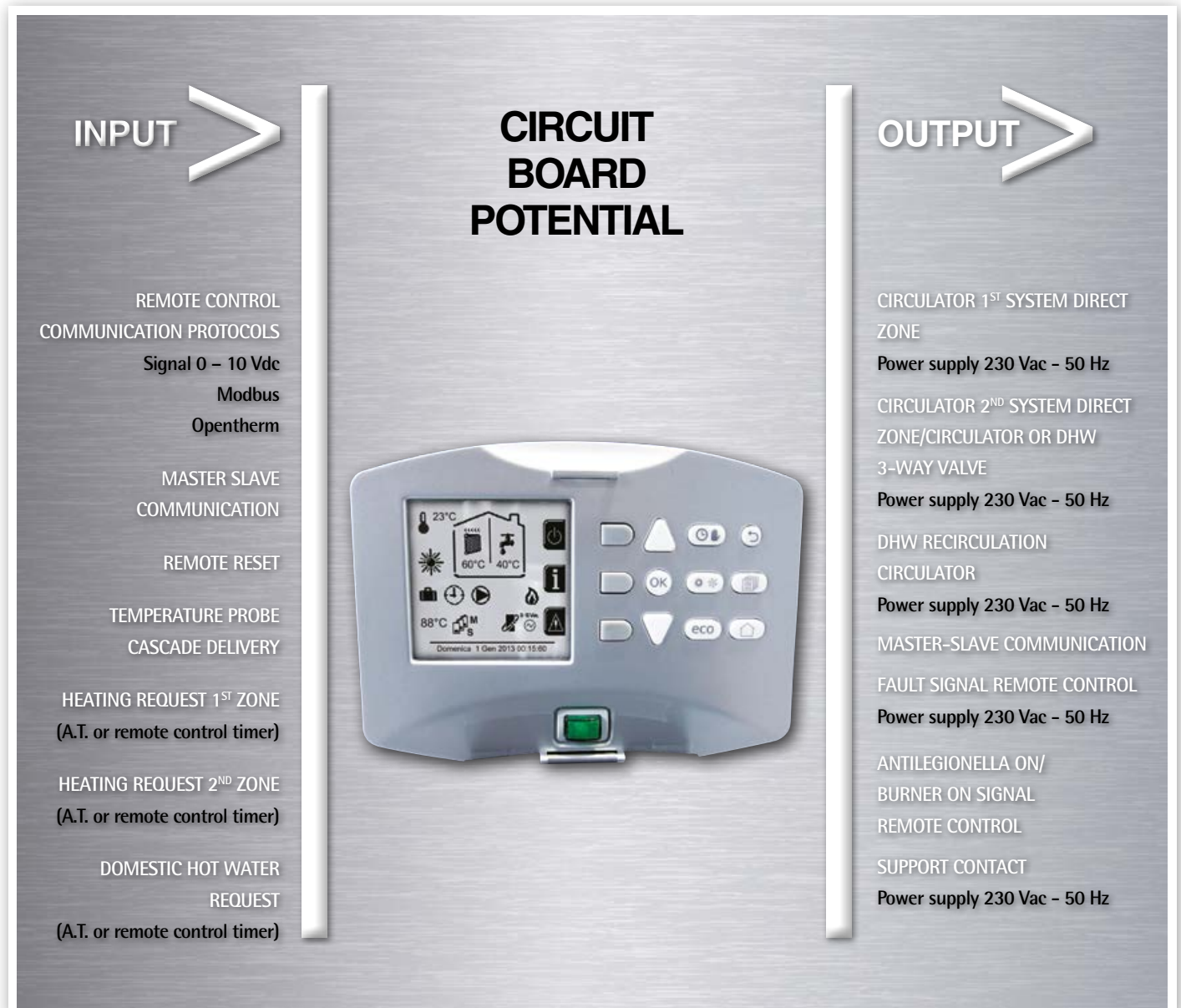

KEY (referred to the diagrams on the next page)

32 Boiler circulator **72a** Room thermostat 1st zone (mixed) **72b** Room thermostat 2nd zone (mixed) **72c** Room thermostat 3rd zone (direct) **138** External probe **139a** Remote timer control 1st zone (mixed) **139b** Remote timer control 2nd zone (mixed) **139c** Remote timer control 3rd zone (direct) **155** Storage tank probe **300** Antilegionella circulator **315a** Mixing valve 1st zone **315b** Mixing valve 2nd zone (mixed) **317a** Safety thermostat 1st zone (mixed) **317b** Safety thermostat 2nd zone (mixed) **318a** Circulator 1st zone (mixed) **318b** Circulator 2nd zone (mixed) **318c** Circulator 3rd zone (direct) **319a** Delivery sensor 1st zone (mixed) **319b** Delivery sensor 2nd zone (mixed) **a** 1st zone (mixed) **b** 2nd zone (mixed) **c** 3rd zone (direct) **d** Storage tank circuit **FZ4 B** Zone control card



CHARACTERISTICS

Control electronics

In the event of OPERA installation in a direct two-zone system (such as a heating circuit and DHW production), the standard electronics can manage the system autonomously without using any optional external equipment.

With regard to mixed systems with high and low operating temperature, the boiler must be coupled with the FZ4 B temperature control module designed to manage a heating system up to three zones, two of which mixed.

CASE A: REPLACEMENT OF THE EXISTING GENERATOR ON A HIGH TEMPERATURE SYSTEM

Heating system consisting of a high temperature heating circuit combined with a DHW storage tank. OPERA electronic control not only ensures the correct operation of the generator but also manages each system component directly.

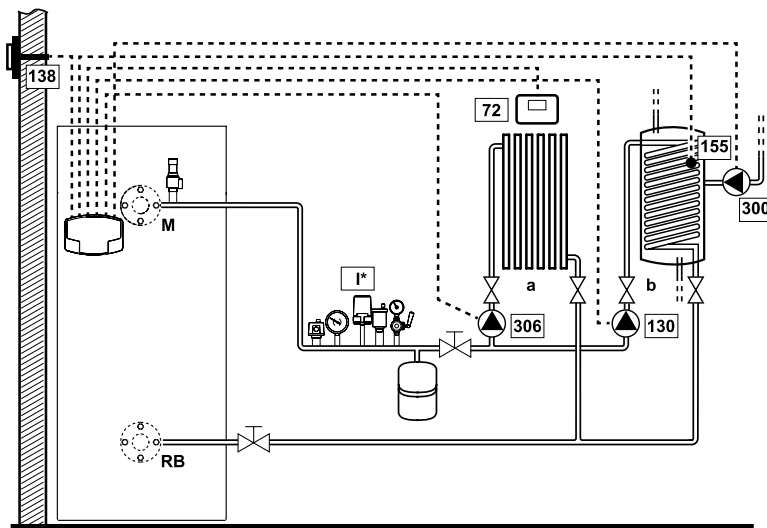

CASE B: NEWLY DESIGNED SYSTEM

Mixed heating system, consisting of a high temperature direct zone, two low temperature zones with mixing valve and DHW storage tank. OPERA electronics can control the equipment of direct circuits (high temperature zone and DHW storage tank), whereas it is combined with FZ4B temperature control connected to the generator via OpenTherm for mixed circuits.

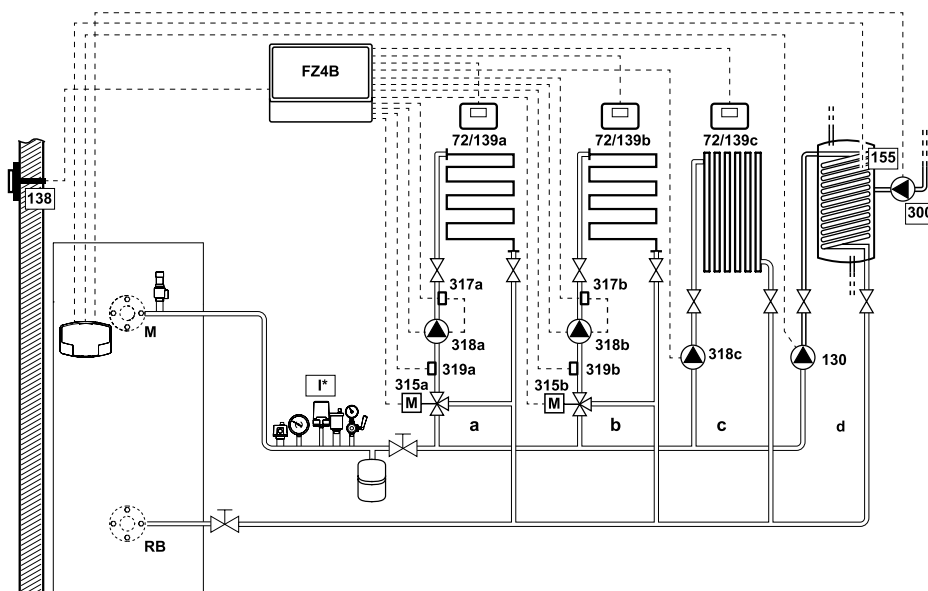

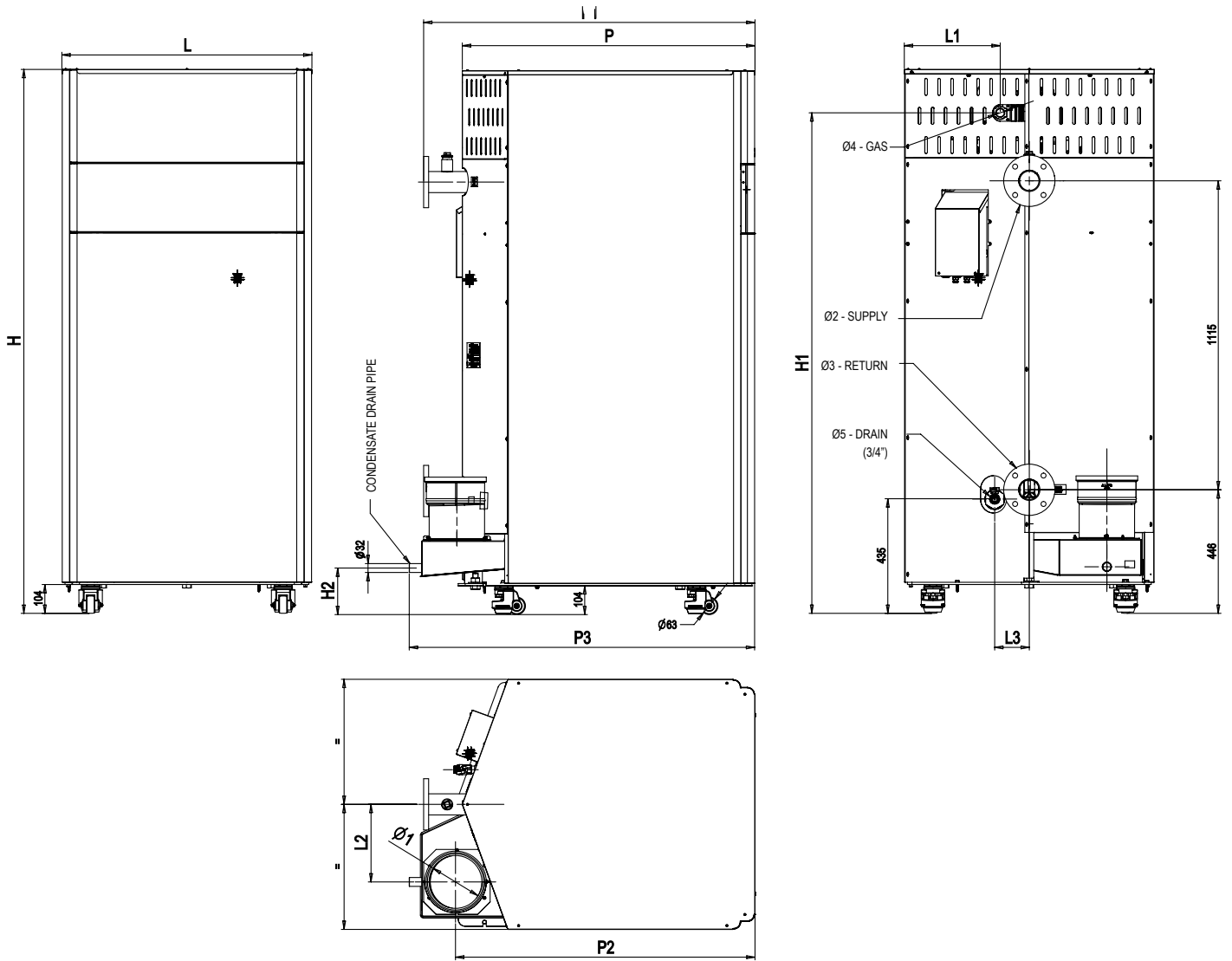

HYDRAULIC, GAS FITTINGS AND FLUE GAS OUTLETS

MODEL		70	125	220	320
Ø 1	Flue gas outlet Ø (mm)	80	100	160	200
Ø 2	System flow	1' 1/4	1' 1/4	2'	DN 65
Ø 3	System Return	1' 1/4	1' 1/4	2'	DN 65
Ø 4	Gas inlet	3/4'	1'	1'	1'
Ø 5	Boiler discharge	3/4'	3/4'	3/4'	3/4'

HEIGHTS AND DIMENSIONS

VOCI	L	L1	L2	L3	H	H1	H2	P	P1	P2	P3
	mm	mm	mm	mm	mm	mm	mm	mm	mm	mm	mm
OPERA 70	540	305	160	100	1885	1800	200	680	765	685	785
OPERA 125	660	385	210	100	1905	1810	195	800	895	815	935
OPERA 220	780	295	240	125	1935	1770	185	925	1055	955	1105
OPERA 320	900	345	280	125	1965	1810	170	1055	1200	1080	1250



TECHNICAL DATA

Summary table

MODEL		70	125	220	320
ERP Class		A	-	-	-
Space heating energy efficiency	η_s %	94	94	94	94
Efficiency and performance					
Heating max heat input	kW	65.5	116	207	299
Heating min heat input	kW	14	23	41	62
Heating max heat output (80/60)	kW	64.4	114	204	294.5
Heating min heat output (80/60)	kW	13.7	22.5	40.2	60.8
Heating max heat output (50/30)	kW	69.9	123.9	221	319.3
Heating min heat output (50/30)	kW	15	24.8	44.2	66.8
Pmax efficiency (80/60)	%	98.3	98.3	98.5	98.5
Pmin efficiency (80/60)	%	98	98	98	98
Pmax efficiency (50/30)	%	106.8	106.8	106.8	106.8
Pmin efficiency (50/30)	%	107.7	107.7	107.7	107.7
Efficiency 30% (30°C)	%	109.6	109.6	109.6	109.6
NOx class		6	6	6	6
Max heating temperature	°C	90	90	90	90
DHW max temperature	°C	70	70	70	70
Max exchanger ΔT	°C	60	60	60	60
Pmax	pascal flue maximum head	200	150	200	200
Min/Max working pressure	bar	0.8 - 6	0.8 - 6	0.8 - 6	0.8 - 6
Structural features					
Water content	litres	160	265	380	530
Empty weight	Kg	180	280	400	500
Width	mm	540	660	780	900
Height	mm	1760	1780	1820	1850
Depth	mm	720	720	870	1020
Electrical features					
Supply voltage	V/Hz	230/50	230/50	230/50	230/50
Electrical protection rating	IP	X0D	X0D	X0D	X0D
Absorbed electric power	W	105	200	260	330
Hydraulic and gas connections					
System delivery		1' 1/4	1' 1/4	2'	DN 65
System return		1' 1/4	1' 1/4	2'	DN 65
Gas inlet		1'	1'	1'	1'
Flue gas outlet \varnothing (mm)		80	100	160	200
Combustion					
Unit type		B23	B23	B23	B23
Pmax combustion efficiency	%	98.3	98.3	98.3	98.3
Pmin combustion efficiency	%	98.7	98.7	98.7	98.7
Flue losses with burner on Pmax	%	1.7	1.7	1.7	1.7
Flue losses with burner on Pmin	%	1.3	1.3	1.3	1.3
Pmax / Pmin fume temperature (80/60)	°C	68 / 60	66 / 60	67 / 61	67 / 61
Pmax / Pmin fume temperature (50/30)	°C	43 / 32	43 / 32	45 / 31	45 / 31
Pmax flue gas flow rate	kg/h	107.1	189.6	338.4	488.8
Pmin flue gas flow rate	kg/h	23.3	39.9	71.1	107.5
CO ₂ Pmax / Pmin	%	9.3 / 9.1	9.3 / 8.7	9.3 / 8.7	9.3 / 8.7
CO O ₂ =0% Pmax	mg/kWh	17	30	40	35
CO O ₂ =0% Pmin	mg/kWh	1	2	2	3
CO O ₂ =0% weighted	mg/kWh	5.5	6	8	20
NOx O ₂ =0% Pmax	mg/kWh	69.7	50	44	41
NOx O ₂ =0% Pmin	mg/kWh	13.3	10	9	10
NOx (O ₂ =0%) weighted	mg/kWh	18	17	22	20
Inner noise level	dB	58	62	72	76



CASCADE INSTALLATION

Modules



It is possible to connect in cascade a minimum of two 70 kW generators to a maximum of three 320 kW generators, in the combinations shown in the table.

For all these configurations, the Company guarantees correct operation and supplies all hydraulic and gas accessories, for the flue gas collector, necessary for the implementation of the "cascade".

HEAT INPUT	HEAT OUTPUT (1)		BANK MODULATION Pmin/Pmax 50/30°C	NO. OF MOD- ULES	COMBINATION OF MODELS		
	80/60°C	50/30°C			1	2	3
kW	kW	kW	kW				
131.0	128.8	139.8	15.0/139.8	2	70	70	-
181.5	178.4	194.9	15.0/194.9	2	70	125	-
232.0	228.0	250.0	24.8/250.0	2	125	125	-
247.0	242.8	264.8	15.0/264.8	3	70	70	125
297.5	292.4	319.9	15.0/319.9	3	70	125	125
323.0	318.0	345.0	24.8/345.0	2	125	220	-
348.0	342.0	375.0	24.8/375.0	3	125	125	125
414.0	408.0	440.0	44.2/440.0	2	220	220	-
439.0	432.0	470.0	24.8/470.0	3	125	125	220
506.0	498.5	540.0	44.2/540.0	2	220	320	-
530.0	522.0	565.0	24.8/565.0	3	125	220	220
598.0	589.0	640.0	66.8/640.0	2	320	320	-
621.0	612.0	660.0	44.2/660.0	3	220	220	220
713.0	702.5	760.0	44.2/760.0	3	220	220	320
818.0	793.0	860.0	44.2/860.0	3	220	320	320
897.0	883.5	960.0	66.8/960.0	3	320	320	320

Note: the Company does not provide the accessories for other configurations not shown in the table

CASCADE INSTALLATION

Practical and smart

Every detail has been designed to simplify cascade installations.

- 1 The hydraulic connections have been positioned at the same heights to simplify connection to the system delivery and return manifolds.
- 2 The satellite flue gas outlet with respect to the generator body and the backflow prevention damper positioned directly on the fan facilitate sizing and implementation of the flue gas manifold (pressurised).
- 3 The OPERA range is coupled with a complete series of accessories for several two or three-generator bank combinations, reaching a maximum output of 960 kW.
- 4 The electronics fitted as per standard was designed to autonomously manage the dynamics of several generators in cascade, with MASTER-SLAVE logic, up to a max. of 6.
- 5 By setting the parameters of the cascade MASTER board, the ignition and shutdown sequence of the various modules can be set and rotated so as to evenly divide the number of operating hours.
- 6 Each complete configuration of the flue gas, hydraulic and gas accessories is certified as "Single generator".

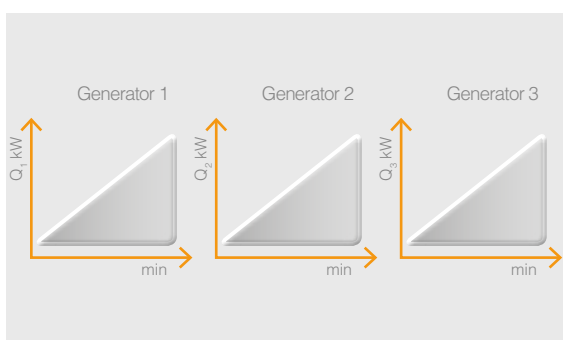

Parallel operation

Parallel operation of the modules provides for simultaneous ignition, power modulation and switch-off of the burners.

This solution allows for maximum system efficiency since most generators running at the lowest power enable maximum condensation.

The modulation range of the system's power is instead limited

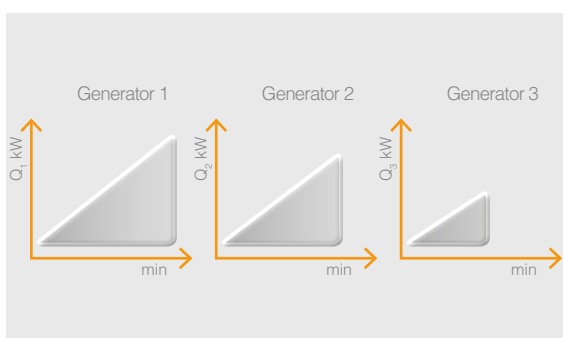

Sequential operation

The ignition and power modulation of the burners with sequential operation enable a wide modulation range that runs from minimum power of a single generator to a total maximum power of all burners running together.

This makes the system more flexible compared to the system's heating requirements, but at the expense of the loss of a certain degree of energy efficiency.



CASCADE INSTALLATION

Flue gas manifold accessories

FLUE GAS MANIFOLD HIGH OUTLET

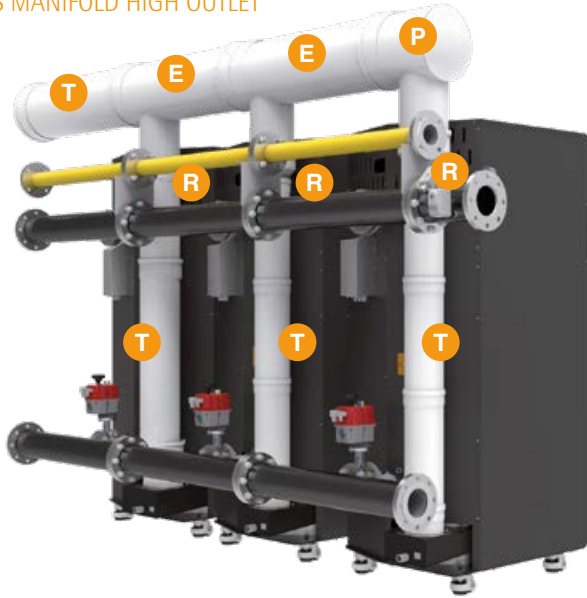

FLUE GAS MANIFOLD MEDIUM OUTLET



FLUE GAS MANIFOLD LOW OUTLET

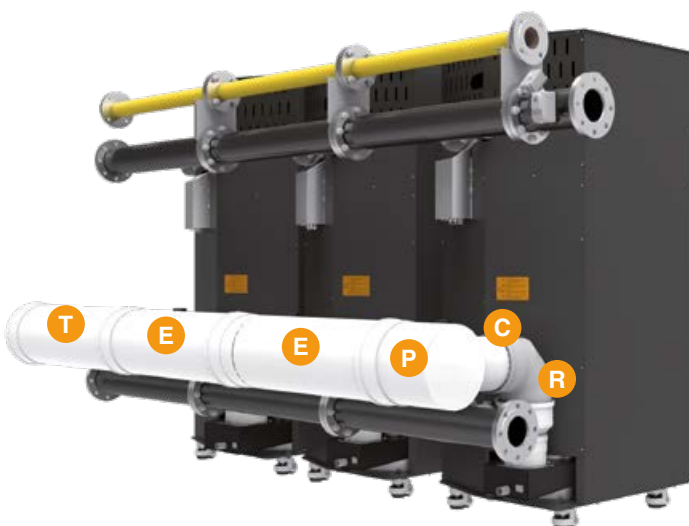

THE RANGE OF FUME ACCESSORIES HAS BEEN DESIGNED IN ORDER TO INSTALL THE DUCT AT DIFFERENT HEIGHTS AND WITH LEFT AND RIGHT OUTLET. THIS CHOICE, IN THE EVENT OF REPLACING AN OLD GENERATOR, SIMPLIFIES THE CONNECTION WITH THE OUTLET OF THE EXISTING FLUE.



P		flue gas manifold closing terminal	160 mm	041066X0
			200 mm	041068X0
			300 mm	041070X0
E		flue gas manifold	160 mm	041067X0
			200 mm	041069X0
			300 mm	041071X0
T		500 mm PPS M/F flue gas pipe	100 mm	041072X0
			160 mm	041074X0
			200 mm	041076X0
T		1000 mm PPS M/F flue gas pipe	100 mm	041073X0
			160 mm	041018X0
			200 mm	041062X0
			300 mm	041063X0
C		PPS M/F 90° bend	100mm	041077X0
			160 mm	041015X0
			200 mm	041060X0
R		PPS M/F reduction	80-100 mm	041078X0
			100-160 mm	041079X0
			160-200 mm	041080X0

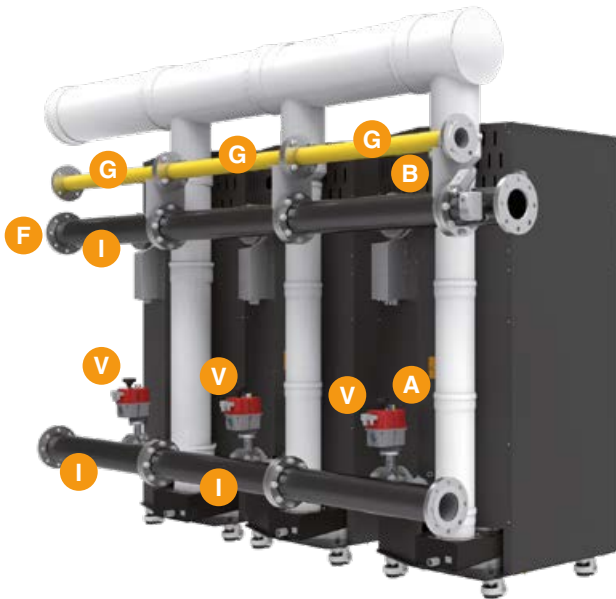

CASCADE INSTALLATION

Hydraulic and gas accessories



G		gas manifold	1' 1/2-1'	042050X0
			2' -1'	042051X0
			2' 1/2-1'	042052X0
I		hydraulic manifold	DN50-1 1/2'	042053X0
			DN65-2'	042054X0
			DN100-DN65	042055X0
V		motorised butterfly vale, 230V - 50Hz powered DN 50 for model 70 and 125	052000X0	
			motorised butterfly vale, 230V - 50Hz powered DN 65 for model 220 and 320	052001X0
A		flange - sleeve	DN50 - 1'1/4	042065X0
			DN65 - 2'	042066X0
A		M - F reduction nipple	2' - 1'1/4	042064X0
B		F - F outlet	1' 1/4	042062X0
			2'	042063X0
F		flange kit (complete with nuts, bolts and gaskets)	DN50	042059X0
			DN65	042060X0
			DN100	042061X0

THE HYDRAULIC AND GAS ACCESSORIES ARE DESIGNED TO SIMPLIFY ASSEMBLY AND ALLOW THE BANK SET-UP TO BE CONNECTED TO SYSTEMS WITH INDEPENDENT OUTLETS ON THE RIGHT OR LEFT FOR EASIER REPLACEMENT OF OLD GENERATORS.



NOTES

A series of horizontal dotted lines for writing notes.



NOTES

Lined area for notes, consisting of multiple horizontal dotted lines.



NOTICE FOR SALES AGENTS:

With a view to constantly improve its production range and customer satisfaction levels, the Company hereby specifies that aesthetic and/or dimensional features, specifications and accessories may be subject to changes.

Please place the utmost care to ensure all technical and/or sales documents (lists, catalogues, brochures, etc.) provided to the final Customer are updated according to the latest edition.

Ferroli SpA

37047 San Bonifacio (VR) Italy - Via Ritonda 78/A

tel. +39.045.6139411

fax +39.045.6100233

www.ferroli.com

export@ferroli.com